

Albero.01 – Product Specification

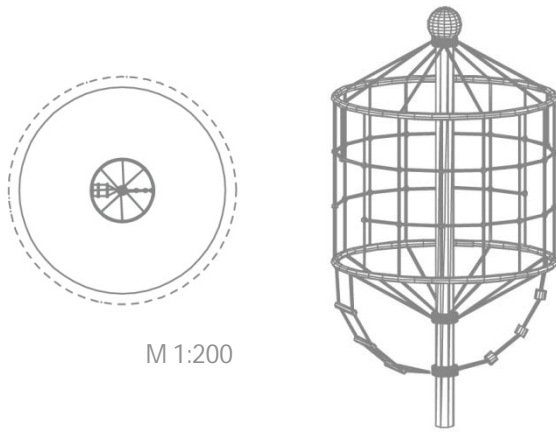

HodgePodge – A variety of study and durable sport and play elements

HodgePodge is a clever and versatile combination of play equipment and climbing structures that can be used anywhere and for numerous activities.

Climbing trees, a Wasp's nest, Volleyball nets for sporting activities, cable rides for fun and excitement.

Albero.01 – At a glance.

Product Family:	HodgePodge	Number of Foundations:	1 pc.
Item Number:	95.200.010	Concrete Volume C20/C25:	1.2 m³ (42.4 ft³)
Children's Age:	5+	Number of skilled installers required:	2
Fall Height (DIN EN 1176):	2.40 m (7'-11")	Installation Time without foundation:	6 hours
Length x Width x Height:	1.7 m x 1.7 m x 3.1 m (5'-5" x 5'-5" x 10'-0")	Dimensions of largest part:	Ø 0.14 m x 4.6 m (6" x 15'-2")
Protective Surfacing Area (DIN EN 1176):	5.9 m x 5.9 m	Weight of heaviest part:	92 kg (203 lbs)
Protective Surfacing Area (ASTM 1487):	5.4 m x 5.4 m (17'-5" x 17'-5")	Shipping Volume:	2.0 m³ (71 ft³)
Minimum space required DIN EN 1176:	26.9 m²	Spare part guarantee:	Lifelong
Minimum space required ASTM 1487:	22.1 m² (237.9 ft³)	Certificate according to EN 1176:	No.: Z2.16.01.10256.257 TÜV Product Service

Technical Data.

The following text can also be used for tenders.

Central mast:

Steel pipes Ø 133mm (5 ¼"), wall thickness 6.3mm (1/4"); anticorrosion treatment and color finish: sandblasting and zinc-/ epoxy-/ polyester-process

Mast node:

Frameworkx®-aluminum ball connector, Ø 250mm (9-13/16"); anticorrosion treatment and color finish: sandblasting and zinc-/ epoxy-/ polyester-process

Outer rings:

Bended Frameworkx®-steel pipes, Ø 48,3 mm (1 7/8"); anticorrosion treatment and color finish: sandblasting and zinc-/ epoxy-/ polyester-process

Rope Ladder:

Rope Ø 16 mm (5/8"); black polyamide rungs: Ø 40 mm (1-3/5")

Climbing rope:

Rope Ø 16 mm; with durable ebonite cylinders; distance between cylinders approx. 300 mm (11-13/16"); ebonite cylinders are fixed to the rope with aluminum ferrules

Netting and suspension ropes:

U-Rope®-round strand ropes with steel cores, Ø 16mm (5/8") – unless otherwise noted; with galvanized wires, external strands covered with non-abrasive UV-resistant Polyester-yarn. Rope crossing points localized with durable, drop forged aluminum-ballknots (no plastic)

Berliner
Berliner Seilfabrik GmbH & Co.
Lengeder Straße 2/4
D-13407 Berlin

Tel. +49.(0)30.41 47 24-0
Fax +49.(0)30.41 47 24-33

info@berliner-seilfabrik.com
www.berliner-seilfabrik.com

